

TEILE

“SLs”



Key features:

2-way active studio monitor loudspeakers with DSP
HF Air Motion Transformer
LF high performance woofer
powered by 3 ABACUS Dolifet amplifier channels
every amplifier channel with DSP
fully time corrected
LF driven by bridge-mode dual-amplifiers
gain control on the plate amp

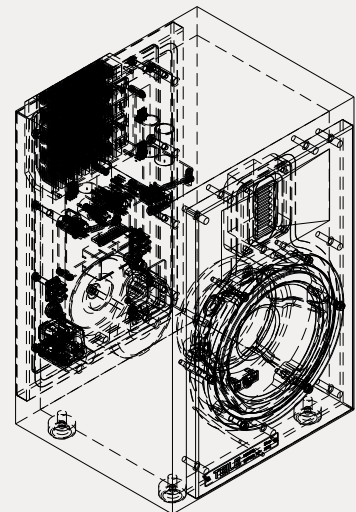

Frequency Response	20 Hz - 20 kHz
Crossover Points	2600 Hz (24 dB/Oct)
Amp power	100W
Driver Configuration	1x LF 6,5", 1x HF AMT
Connectors	XLR, chinch
Gain Control	Input Gain (-6 dB ... +6 dB) Bass Pad (-8 dB ... +2 dB below 100 Hz) Bass Roll-off (16Hz ... 80Hz)
Enclosure	Closed
Finish	Santos Palisander veneer, supermatt ceramic black
Weight	9.5 kg

3D file:

[TEILE SLs.USDZ](#)