

# TEILE

## “SLm”



### Key features:

3-way active studio monitor loudspeakers with DSP  
HF Air Motion Transformer  
MF dome midrange  
LF high performance woofer  
powered by 4 ABACUS Dolifet amplifier channels  
every amplifier channel with DSP  
fully time corrected  
LF driven by bridge-mode dual-amplifiers  
gain control on the plate amp

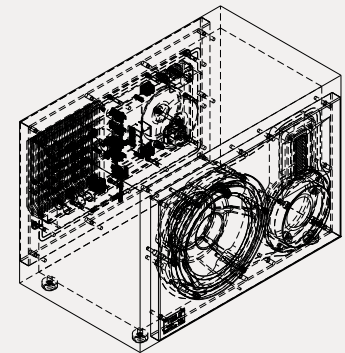

Frequency Response	20 Hz - 20 kHz
Crossover Points	500 Hz and 2000 Hz (24 dB/Oct)
Amp power	150W
Driver Configuration	1x LF 8", 1x MF 2" dome, 1x HF AMT
Connectors	XLR, chinch
Gain Control	Input Gain (-6 dB ... +6 dB) High Shelf (-3 dB ... +3 dB above 1 kHz) Bass Pad (-8 dB ... +2 dB below 100 Hz) Bass Roll-off (16Hz ... 80Hz)
Enclosure	Closed
Finish	Santos Palisander veneer, supermatt ceramic black
Weight	19kg

3D file: [TEILE SLm.USDZ](#)